

GRP Mini Mesh

Our GRP Mini Mesh grating is a specially designed and moulded non-slip composite floor solution, constructed from the highest quality fibreglass making it chemical, rust, and corrosion resistant, and lightweight, whilst also offering longevity and durability. With limited tooling and installation costs, we can offer a vast range of standard length and width sizes, plus our in-house cutting service means we can offer bespoke sizes for that perfect fit.

Optional clips or clamps are available to purchase if required.

Features

- ◆ **Typical applications:** Perfect solution for platforms, walkways, pontoons, flooring, ramps and covers for industrial or construction sites, chemical and shipping industries as well as offshore oil rigs.
- ◆ **Material:** GRP - Glass reinforced polyester with a resin coated gritted surface.
- ◆ **Cleaning:** Using a stiff brush will normally be sufficient to remove everyday dirt and debris. For more stubborn dirt, wash with warm water and a mild detergent, or a pressure washer on a low-pressure setting can also be used.
- ◆ **Sustainability:** REACH compliant.
- ◆ **Warranty:** Lifetime.

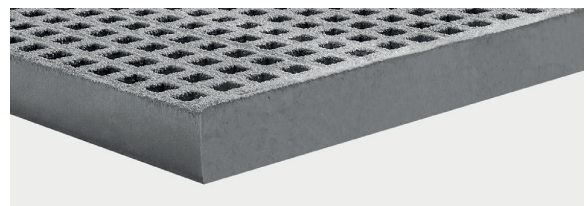
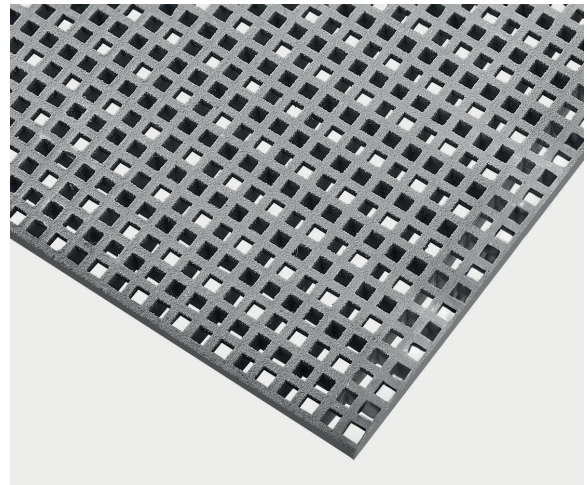

Suitable for indoor and outdoor use

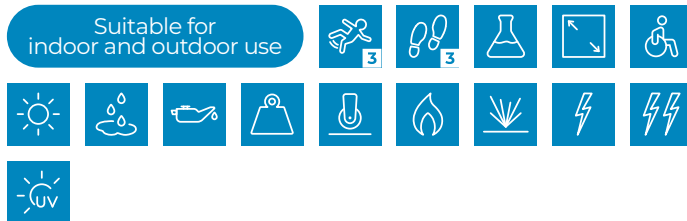

For more information about this product or, to place an order [click here](#)

Code	Size	Thickness	Weight	Colour
GR4913-30GY	4038mm x 1262mm	30mm	95kg	Grey
MC-19SS	M Clip		0.02kg	Stainless Steel
JC-38SS	J Clamp		0.07kg	Stainless Steel
FC45SS	Square Fixing Clip 45mm		0.02kg	Stainless Steel
FD45SS	Fixing Disc 45mm		0.1kg	Stainless Steel
M8-35SS	M8 x 34mm Bolt/Nut/Washer Set		0.03kg	Stainless Steel

Please note, cutting tolerance +/- 5mm

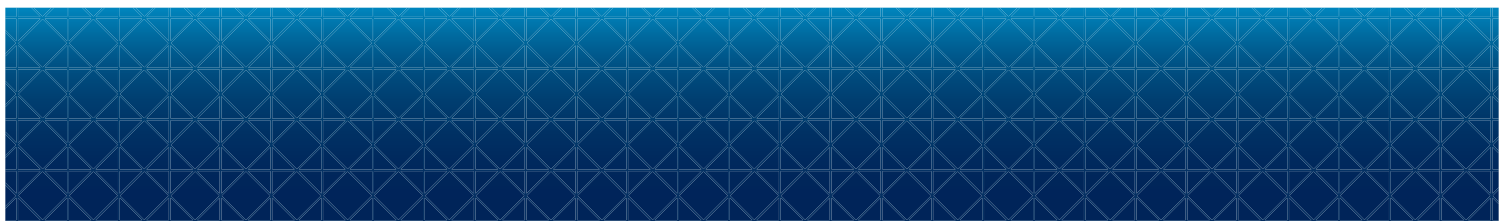

GRP Mini Mesh

Technical Specification

Slip resistant:	Excellent slip resistance to level 3
Wear resistant:	Excellent wear resistance to level 3, suitable for heavy footfall
Chemical resistant:	Yes
Cut to size:	Yes, tolerance +/- 5mm
Disability friendly:	Yes, the low profile makes it suitable for wheelchair users
Dry area:	Yes
Wet area:	Yes
Oily and greasy area:	Yes
Heavy area:	Yes
Wheeled area:	Yes
Environment:	Suitable for indoor and outdoor use
Flame retardant:	Yes
Impact resistant:	Yes
Non-conductive (Electrical):	Yes
Non-conductive (HV Electrical):	Yes

Product testing:	◆ Slip resistance
	◆ Tested to BS 7976.2 - PTV 'Extremely Low' for wet and dry conditions, PTV 'Low' for oily and greasy conditions
	◆ Coefficient of Friction (CoF): Dry 72; Wet 69 and Oil 56
	◆ Fire certificate
	◆ Standard ISO Resin - BS 476 Part 7 Class 2
	◆ ASTM-E84 Flame Spread 25, Smoke Density 325
	◆ Load certificate
	◆ BS EN 124 – Class A15
	◆ UV certificate
	◆ UV Weather ISO 4892-2 Xenon Arc 5000hrs

Sustainability: REACH (Registration, Evaluation, Authorisation and Restrictions of Chemicals)

Temperature resistance: -50°C to +110°C

UV Resistant: Yes

GRP Mini Mesh

* The differences between Class 1 and Class 2

Both are classifications of the surface spread of flame test (BS 476 part 7). They refer to the degree of flame spread on an ignited panel 900mm x 230mm cut from a laminate. The panel is exposed at right angles to a radiant panel to reproduce the effect of a fire on an adjoining wall or ceiling. It is ignited at the hotter end and allowed to burn for 10 minutes. Flame spread is measured along a line 75mm from the base.

- ◆ Class 1 rating is given if the spread of flame is no greater than 165mm.
- ◆ Class 2 rating is given if the spread of flame is no greater than 215mm in the first 1½ minutes and on overall spread of no more than 455mm.
- ◆ Class 0 rating is a Building Regulations rating and not a British Standard Classification. To attain Class 0, a sample must meet Class 1 for spread of flame and also meet the fire propagation requirements of BS476 Part 6.
- ◆ The Part 6 test was introduced because investigations into the growth of building fires showed that spread of flame was not the only significant factor. Fire propagation (or the amount of heat added to a fire by the energy output of burning materials) was also an important consideration.

Pendulum Slip Testing

Pendulum slip testing was carried out on 17.02.23 and concluded that our GRP Mini Mesh achieved the highest slip resistant classification of 'Extremely Low' pedestrian slip risk for wet and dry conditions and 'Low' for oily/greasy areas.

Pendulum Test Value (PTV)	Slip Risk
0 - 24	High
25 - 35	Moderate
36 - 64	Low
65+	Extremely Low

Pendulum test results	Coefficient of Friction (CoF)		
	Dry	Wet	Oil
Standard Grit	72	69	56

GRP Mini Mesh

GRP Care and Maintenance

◆ **Cleaning**

Being a highly durable material, using a stiff brush will normally be sufficient to remove everyday dirt and debris, and for more stubborn dirt, wash with warm water and a mild detergent. A pressure washer on a low-pressure setting can also be used, however, care should be taken to ensure that this does not harm the integrity of the fixings being used, likely to be screws and/or adhesive.

We recommend always testing any cleaning method and liquids on a small inconspicuous section before applying to the full area. Any spills should be cleaned immediately in line with the product data sheets and the company's own safety procedures.

◆ **General Routine Maintenance**

The integrity of all fixings should be checked on a regular basis to ensure that the mini mesh remain in a firm and stable position. The gritted surfaces and GRP substrate should also be checked regularly, the frequency would depend on the nature and volume of footfall. As a guide, for high traffic areas a monthly inspection would be advisable.

◆ **Life expectancy**

Our GRP Mini Mesh have a design life of 10+ years, however, the life expectancy of any flooring product will be dictated by the nature and volume of the traffic it receives. Factors such as footwear type and material, weight of individual, pedestrian or non-pedestrian traffic, and any contamination such as dirt or grit are all factors that will influence the life term through natural wear and tear of the GRP.

Installation

◆ **Handling**

Safe handling practices should always be employed. GRP should also be stored face down to prevent damage.

◆ **Cutting**

Minor adjustments, small cut outs, can be made with a hacksaw or a jigsaw with a suitable blade. We offer a full in-house cutting service, however, should you wish to cut the mini mesh yourself, this is easily to do by using orbital cutting equipment with either a stone or diamond blade. Cutting should be carried out externally, or where there is dust extraction, or suitable ventilation. Appropriate protective equipment should always be worn.

We're here to help

Should you have any questions about our GRP Mini Mesh, or need advice regarding care, maintenance or installation, we're only a phone call away.





GRP Mini Mesh

Closed Edge Sizes

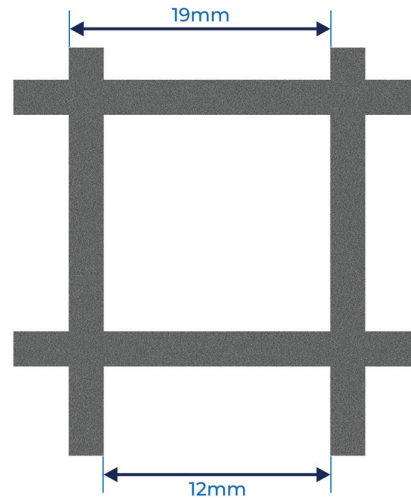

Load Bearing Specification

Load bearing capacity and panel deflection depend on panel thickness and unsupported span.

Mini Mesh Grating - Load and Deflection (Kg/metre @ 0.5% Deflection)

Panel Thickness (mm)	Span Type of Loading	250mm	500mm	600mm	750mm	1000mm	1200mm	1500mm	2000mm
30	Point Load	1,170kg	463kg	322kg	206kg	156kg	81kg	38kg	29kg
	UDL	2,433kg	1,559kg	902kg	462kg	195kg	113kg	58kg	24.5kg

GRP Mini Mesh

GRP Grating Accessories

GRP grating clips and clamps complement our range of GRP grating and provide best-practice fixing methods for fastening and joining grating panels.

M Clip

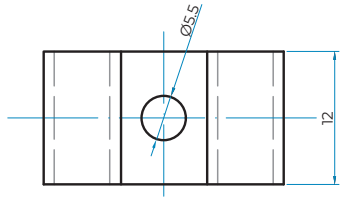
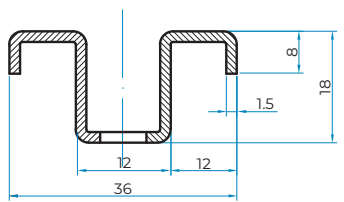

J Clamp

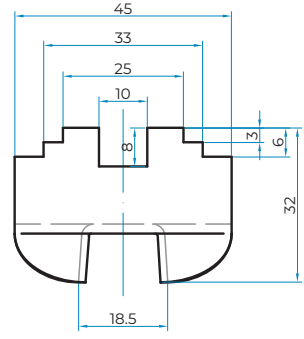
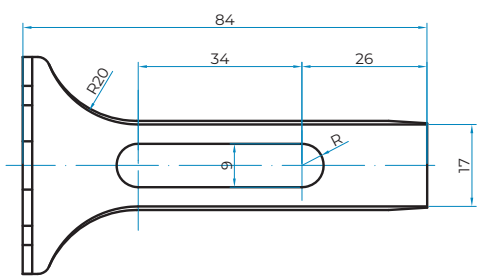

Square Fixing Clip 45mm

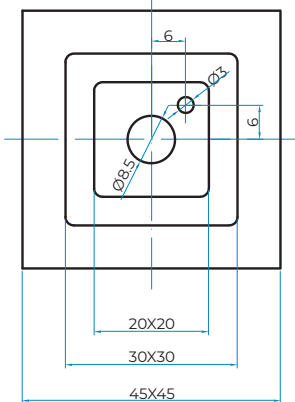
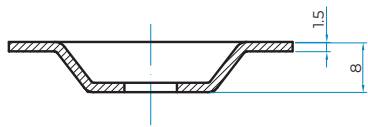

GRP Mini Mesh

Fixing Disc 45mm

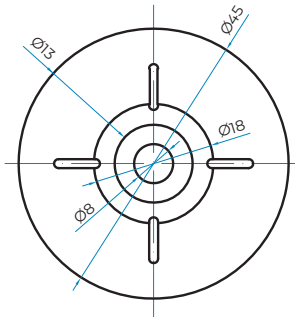
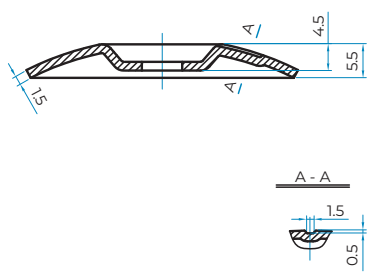

Installation Diagrams

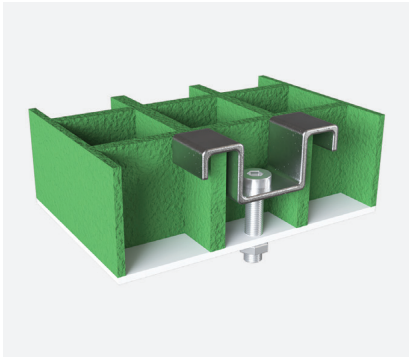

M Clip

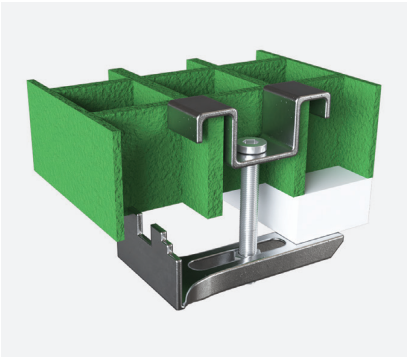

J Clamp

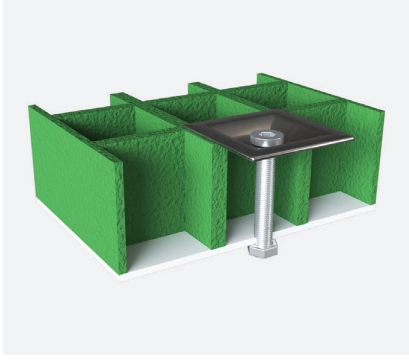

Square Fixing Clip

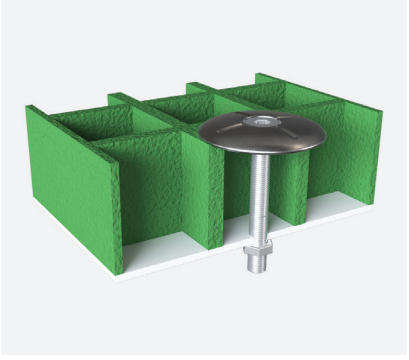

Fixing Disc



GRP Mini Mesh

GRP Chemical Resistance Chart

Environment	%Conc.	Max.Oper. Temp.F/C.
Acetic Acid	50	125/52
Aluminum Hydroxide	100	160/71
Ammonium Chloride	ALL	170/77
Ammonium Bicarbonate	15	125/52
Ammonium Hydroxide	28	N/R
Ammonium Sulphate	ALL	170/77
Benzene	ALL	N/R
Benzoic Acid	SAT	150/66
Borax	SAT	170/77
Calcium Carbonate	ALL	170/77
Calcium Nitrate	ALL	180/82
Carbon Tetrachloride	100	N/R
Chlorine Dry Gas	-	140/60
Chlorine Water	SAT	80/27
Chromic Acid	5	70/21
Citric Acid	ALL	170/77
Copper Chloride	ALL	170/77
Copper Cyanide	ALL	170/77
Copper Nitrate	ALL	170/77
Ethanol	50	75/24
Ethylene Glycol	100	90/32
Ferrous Chloride	ALL	170/77
Formaldehyde	50	75/24
Glucose	100	170/77
Gasoline	100	80/27
Glycerine	100	150/66
Hydrobromic Acid	50	120/49
Hydrochloric Acid	37	75/24
Hydrogen Peroxide	5	100/38
Lactic Acid	ALL	170/77

Environment	%Conc.	Max.Oper. Temp.F/C.
Lithium Chloride	SAT	150/66
Magnesium Chloride	ALL	170/77
Magnesium Nitrate	ALL	140/60
Magnesium Sulphate	ALL	170/77
Mercuric Chloride	100	150/66
Mercurous Chloride	ALL	140/60
Nickel Chloride	ALL	170/77
Nickel Sulphate	ALL	170/77
Nitric Acid	20	70/21
Oxalic Acid	ALL	75/24
Perchloric Acid	10	N/R
Phosphoric Acid	100	120/49
Potassium Chloride	ALL	170/77
Potassium Dichromate	ALL	170/77
Potassium Sulphate	ALL	170/77
Propylene Glycol	ALL	170/77
Sodium Acetate	ALL	160/71
Sodium Bisulphate	ALL	170/77
Sodium Bromide	ALL	170/77
Sodium Cyanide	ALL	170/77
Sodium Hydroxide	N/R	N/R
Sodium Nitrate	ALL	170/77
Sodium Sulphate	ALL	170/77
Stannic Chloride	ALL	160/71
Sulfuric Acid	25	75/24
Tartaric Acid	ALL	170/77
Vinegar	100	170/77
Water Distilled	100	170/77
Zinc Nitrate	ALL	170/77
Zinc Sulphate	ALL	170/77