

Bull Barrier Installation Guide



sales@starttraffic.uk | 01905 794 875 | www.starttraffic.uk

Contents

1. Description of the Bull Barrier system
2. PPE and safety
3. Barrier installation
4. Reinforcement bar installation
5. Barrel installation
6. Fence installation
7. For full compliance with EN1317 T2

1. Bull Barrier System

The BULL BARRIER consists of steel base sections, hot dip galvanised and then powder coated. Each base unit measures 1500mm x 516mm x 410mm and weighs 46kg. Reinforcement bars and fences can be added as the job demands.

The BULL BARRIER is extremely quick and easy to assemble due to its patented slot and hinge design. This means minimum risk of injury to workforce personnel and less time of traffic flow obstruction during assembly.

Please follow the detailed safety installation guidelines below to minimise risk of injury.

2. Personal Protective Equipment

During the installation of the BULL BARRIER we recommend that the following PPE be used. A risk assessment is detailed below.

Activity	Risk	Precautions
Loading and Unloading	<ol style="list-style-type: none">1. Injury to heads.2. Injury to feet.3. Injury to hands or fingers4. Injury as a result of manual lifting5. Death or injury as a result of manoeuvring delivery vehicle.6. Injury from collision with passing traffic.	<p>Wear hard hats.</p> <p>Wear steel toe capped safety footwear.</p> <p>Wear protective construction gloves with rubber grips on fingers and palms. Use correct tools.</p> <p>Use proper lifting technique. Minimum 2 men per base unit.</p> <p>Wear high visibility long sleeved jackets.</p> <p>All lorry movements to be under the control of a competent banksman.</p> <p>Traffic management in accordance with the Traffic Signs Manual (Chapter 8) & subsequent guidance.</p>

<p>Connection of units and reinforcement bars and fences</p>	<p>1. Injury to heads.</p> <p>2. Injury to feet</p> <p>3. Injury to hands or fingers.</p> <p>4. Injury as a result of manual lifting.</p> <p>5. Injury from collision with passing traffic.</p> <p>6. Wrist injury from impact wrench</p>	<p>Wear hard hats.</p> <p>Wear steel toe capped safety footwear.</p> <p>Wear protective construction gloves with rubber grips on fingers and palms. Use correct tools.</p> <p>Keep 2 hands on power tools when in use</p> <p>Use proper lifting technique. Minimum 2 men per base unit.</p> <p>Wear high visibility, long sleeved jacket.</p> <p>Traffic management in accordance with the Traffic Signs Manual (Chapter 8) & subsequent guidance.</p> <p>Work force should be trained in using the impact wrench safely. Always use 2 hands.</p>
---	---	---

3. Installation of BULL BARRIER base units -46kg

BULL BARRIER has been designed to make it easy to install on uneven terrain and around corners. Follow the installation guide below for quick and easy installation.

1. Place the first barrier on the ground.
2. Slot the lifting bars through the holes at each end of the next barrier.
3. Align the hinge of this barrier with the slot on the first barrier.
4. Angle the barrier up until the slot and hinge engage then lower it to the floor.
5. Repeat.

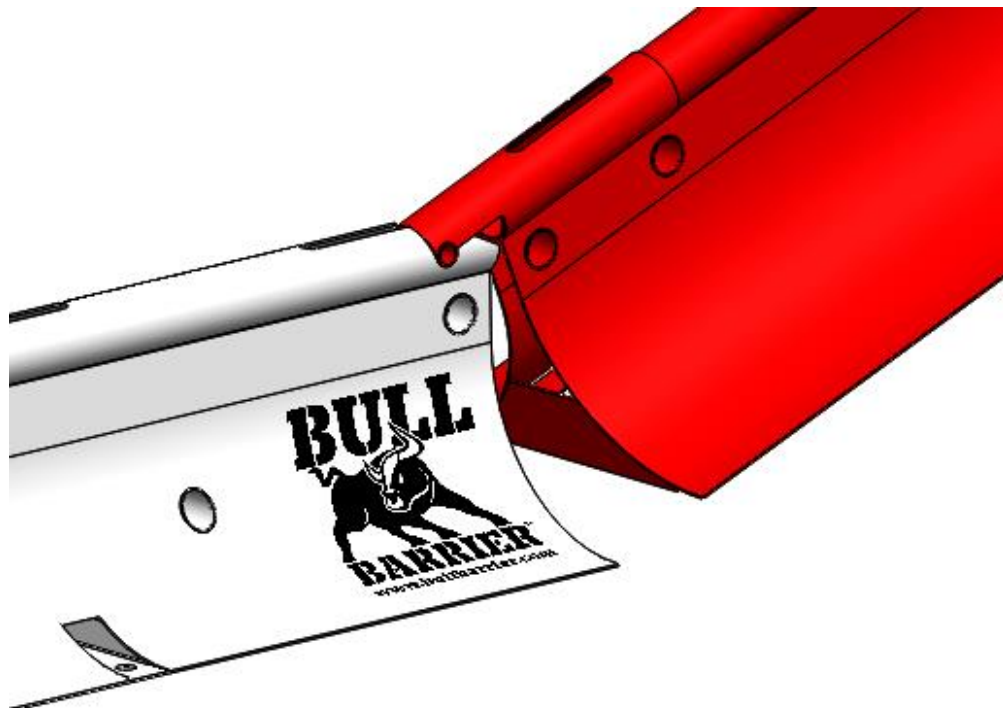

4. Installation of Reinforcement Bars -18kg

Reinforcement bars should be used in conjunction with L-bars when used in areas with traffic. Reinforcement bars come in 3m and 1.5m lengths. 1.5m bars are useful for bends and at the end of a line of BULL BARRIERS.

For installation, you will need a battery powered impact wrench for quickest installation.

1. Slot the bar into the holes on the base unit (you may need to flip the bar over).
2. If using the L-bars, hang these on the reinforcement bar rods now showing on the other side. The L-bar **overlaps 2 reinforcement bars**. Begin threading the nuts on to the rods by hand. Use the impact wrench to tighten the nuts.

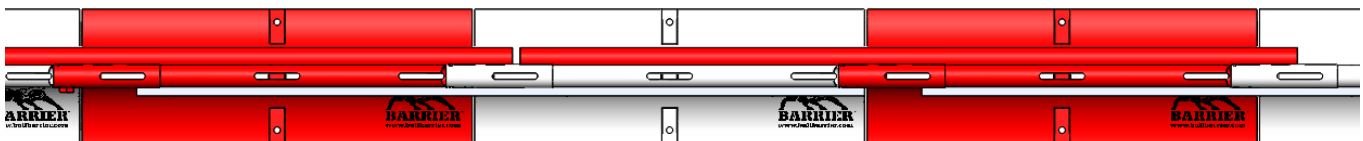
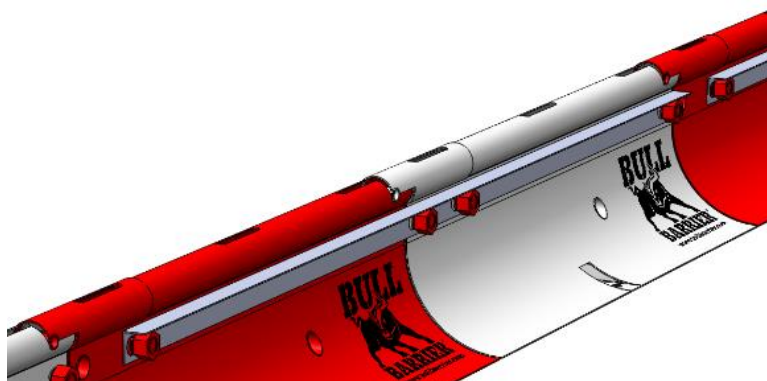
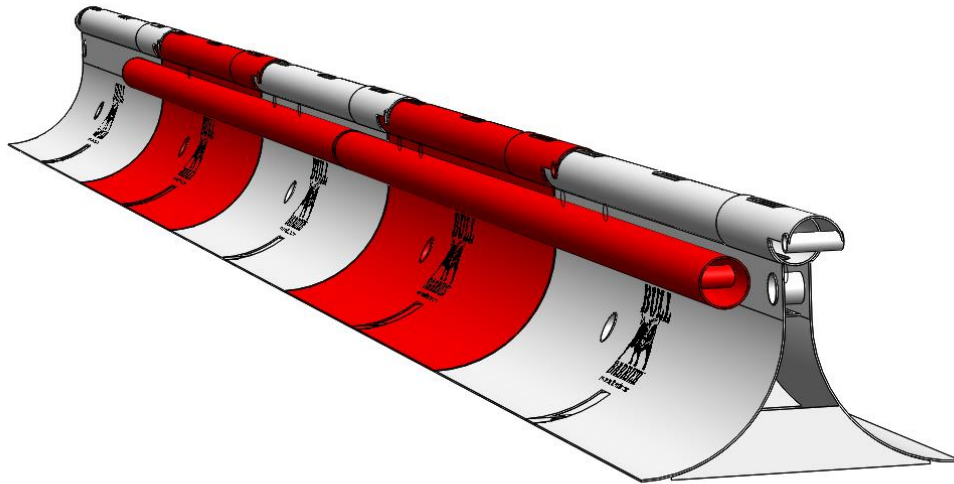

5. Installation of the Tight Corner/Terminal End Bull Barrel

The BULL BARREL can be used as a terminal end to a line of barriers or to allow corners of up to 90° to be installed without a break in the line.

1. If barrels are being used as terminal ends, it is easiest if the first barrel is placed before any barriers.
2. The Bull Barrel uses the same slot and hinge design as the base units.
3. For corners, the double slotted tube rotates allowing for any angle between 90° and 180°.
4. It can also be used to create T-sections.

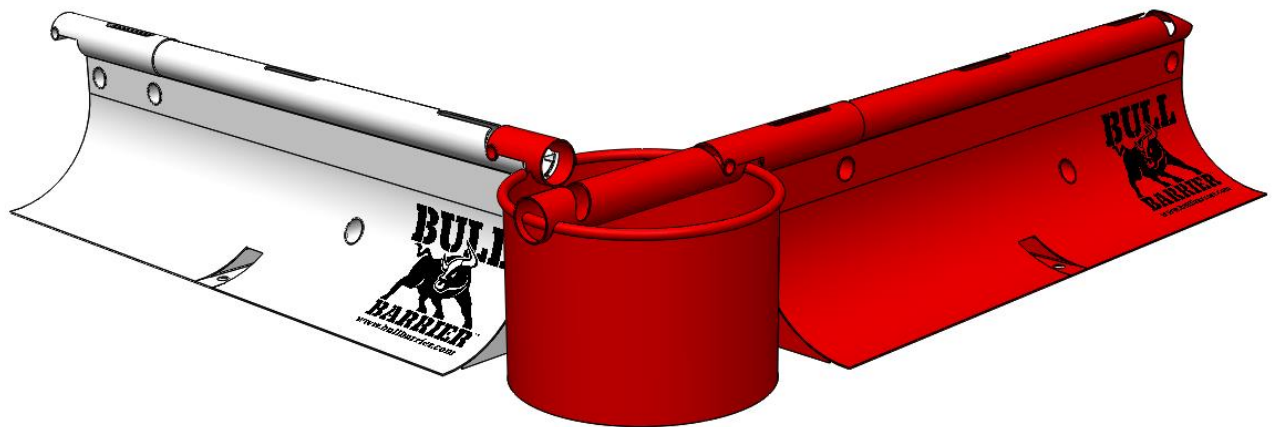

6. Installation of Fences

Pedestrian Extension

Each pedestrian panel is 1.5m long and join 2 base units together. They can be inserted into any of the slots on the tops of the base units. Pedestrian extension panels should be joined together using standard couplers. Pedestrian extensions make the unit 1m high.

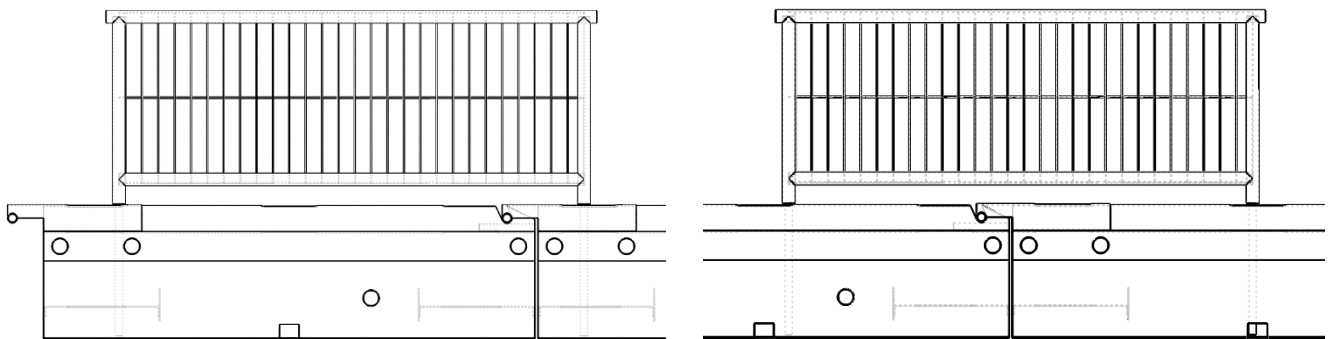

Installation of Anti-climb Extensions:

Each anti climb panel is 3m long and join 3 base units together. They can be inserted into any of the slots on the tops of the base units. Anti-climb extension panels should be joined together using standard couplers. Anti-climb extensions make the unit 2m high.

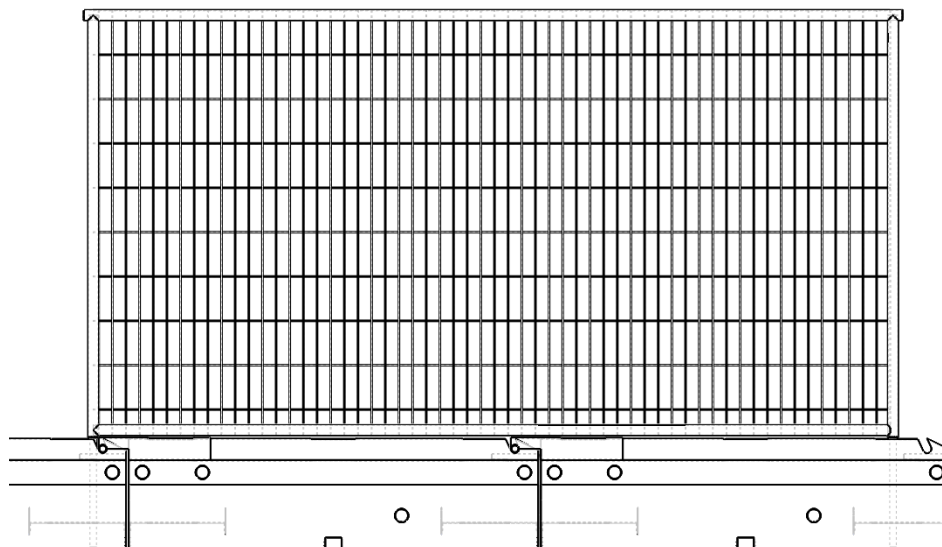

Fence couplers

They are used to clamp the panels together once the system is fully assembled.

Clamping the panels together restricts movement and helps prevent theft.

We recommend the use of one pair of couplers on pedestrian extensions and two pairs on anti-climb extensions.

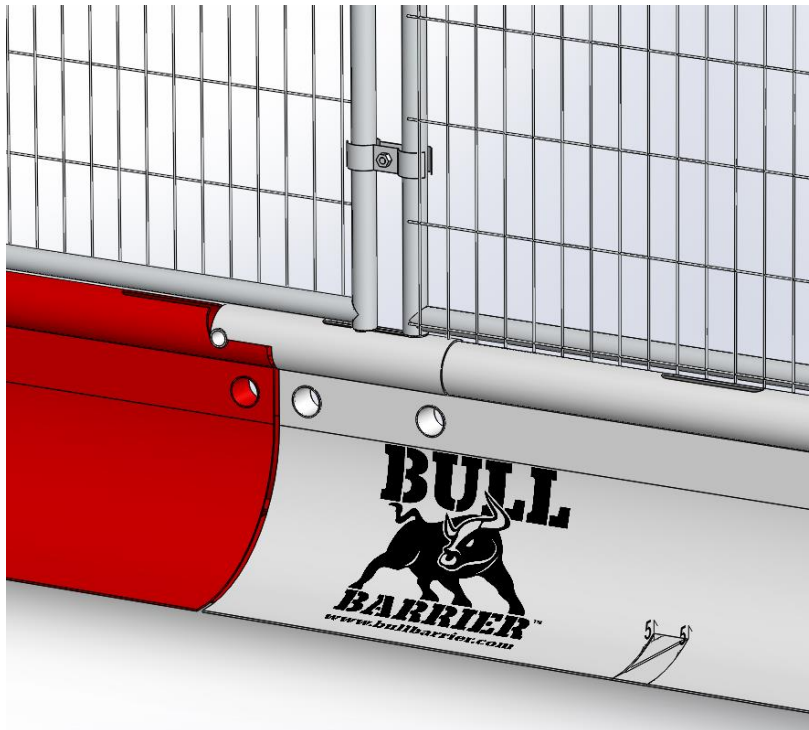

7. For full compliance with EN1317 T2

For full compliance with the crash test standard the Bull Barrier system must be set up as follows:

- Barriers correctly installed
- Reinforcement bars installed
- L-bars installed
- Anchor bolts installed.
- NO fencing installed.

-Installed in compliance with the National Highways Sector Scheme and Lantra training.

Anchor installation

-4 Anchors for every 76.5m of Bull Barrier.

Anchor type: SSR-CA55 stainless steel anchor bolts (- M20 x 260mm -) installed with VDP capsules (170mm minimum embedment depth) OR equivalent system.

