

DIMENSION	15561				
	ITEM REFERENCE				
	02362 (LV02362)	CM148 (LVCM148)	CM149 (LVCM149)	CM1186 (LVCM1186)	CM913 (LVCM913)
A - INTERNAL LENGTH	110.00 [4.331]	170.00 [6.693]	110.00 [4.331]	125.00 [4.921]	120.00 [4.724]
B - INTERNAL WIDTH	49.00 [1.929]	49.00 [1.929]	49.00 [1.929]	85.00 [3.347]	40.00 [1.575]
C - INTERNAL THICKNESS	5.00 [0.197]	5.00 [0.197]	5.00 [0.197]	5.00 [0.197]	5.00 [0.197]
D - CAP INTERNAL LENGTH	150.00 [5.906]	150.00 [5.906]	150.00 [5.906]	150.00 [5.906]	100.00 [3.937]
E - WALL THICKNESS	2.25 [0.089]	2.25 [0.089]	2.25 [0.089]	3.00 [0.118]	2.25 [0.089]
MATERIAL	PVC	PVC	PVC	PVC	PVC
SHORE HARDNESS	85A +/- 5	85A +/- 5	70A +/- 5	70A +/- 5	70A +/- 5
COLOR	MUSTARD YELLOW	YELLOW	MUSTARD YELLOW	YELLOW	YELLOW

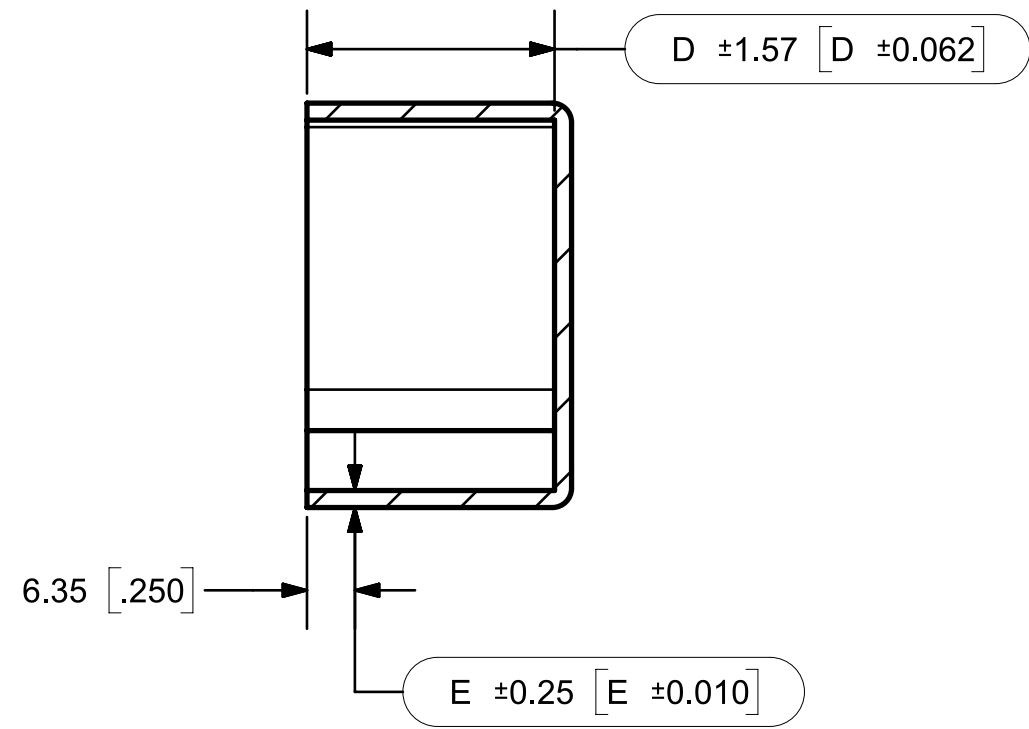
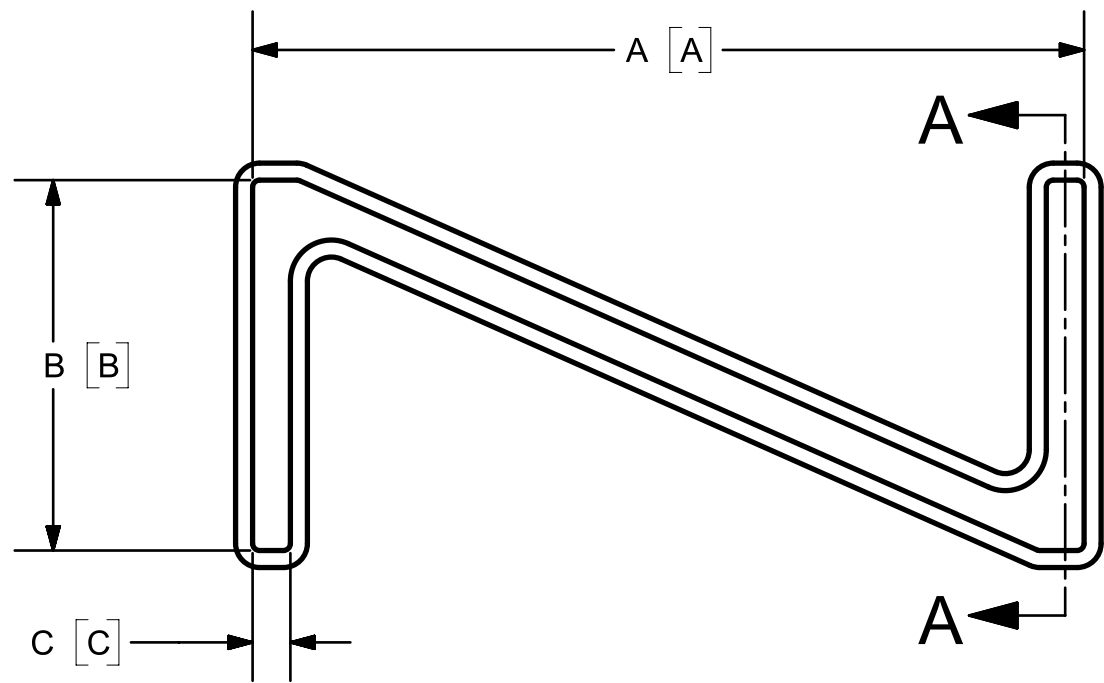

SECTION A-A

NOTES:

1. DIMENSIONS IN [ ] ARE INCHES.
2. DIMENSIONS INSIDE OVALS ARE INSPECTION DIMENSIONS.  
ALL OTHER DIMENSIONS ARE REFERENCE.
3. SURFACE TYPE: SMOOTH WITH MEDIUM GLOSS
4. REFERENCE DRAWING ONLY.