



# MANHOLE GUARDIAN™

By Sweetnam & Bradley

Protects open manholes, whilst still allowing full access for the workforce  
Designed & Manufactured in the UK

- STRONG BUT LIGHT WEIGHT
- QUICK & EASY TO INSTALL & REMOVE
- FITS SQUARE, RECTANGULAR & CIRCULAR MANHOLES
- TESTED & APPROVED BY CERTEX UK LTD TO 440kg (PC99)
- CLOSES FOR EASY TRANSPORT
- COST EFFECTIVE PROTECTION FOR OPEN MANHOLES
- MANUFACTURED FROM GALVANISED & POWDER COATED STEEL FOR FULL WEATHER PROTECTION
- FULLY ADJUSTABLE, FITS MANHOLES FROM 370 TO 900 mm
- PROTECTS THE PUBLIC & YOUR WORKFORCE

Quick and easy to install



Protects, whilst allowing access to the manhole



Compact & light weight for easy transportation

Adjustable positioning posts to secure Manhole Guardian™ into place

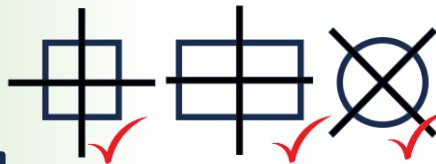

Suitable for Square, Rectangle & Round manholes

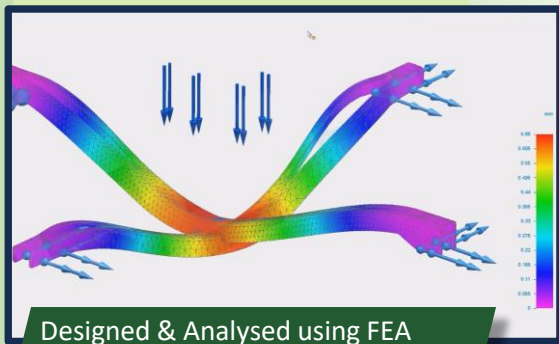

Designed & Analysed using FEA

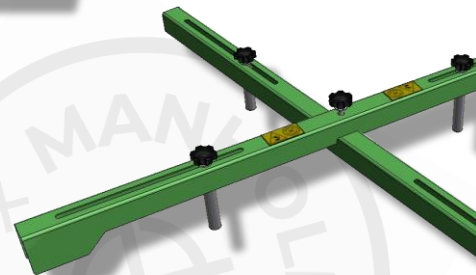

Designed & Manufactured in the UK

Available to buy from [www.startsafety.uk](http://www.startsafety.uk)

**START SAFETY**

Tested and certified to 440kg



**sb** SWEETNAM & BRADLEY LTD  
SHEET METALWORK SPECIALISTS



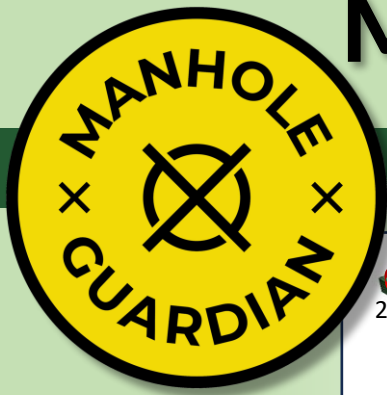

# MANHOLE GUARDIAN™

By Sweetnam & Bradley

## OPERATING INSTRUCTIONS

**sb** SWEETNAM &  
BRADLEY LTD  
SHEET METALWORK SPECIALISTS

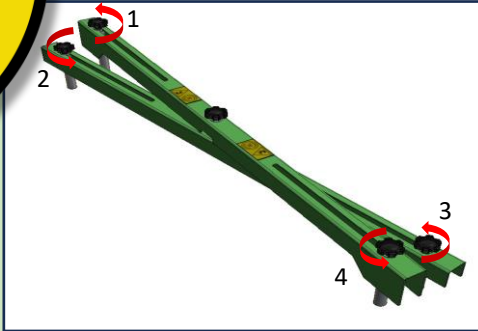

**1** Slacken the 4 No. location posts wheel bolts.

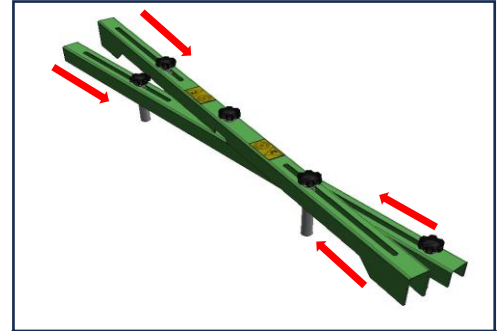

**2** Slide all 4 Location Posts toward the centre.

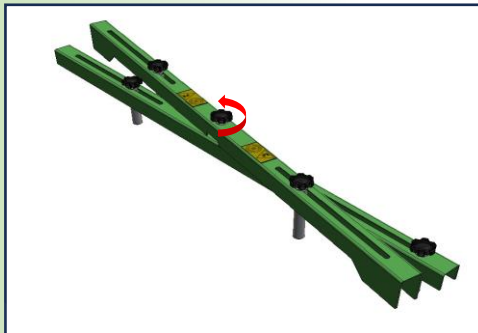

**3** Slacken the central wheel bolt.

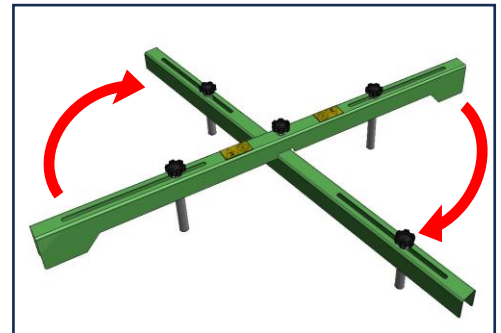

**4** Rotate the upper member to form a cross

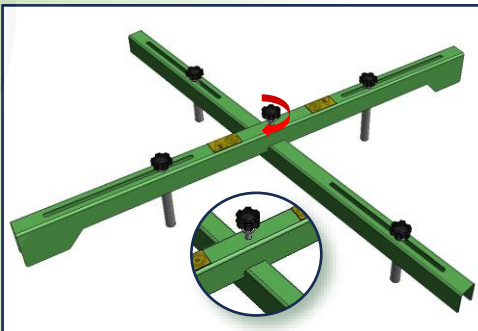

**5** Ensure the cutout in the top member locates securely over the bottom member & tighten the central wheel bolt.

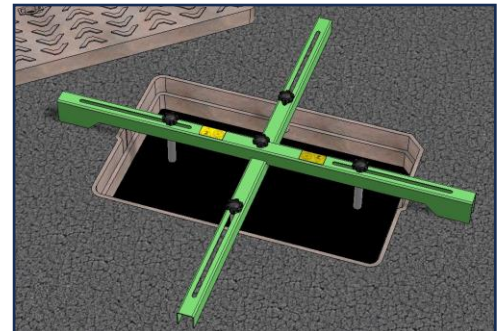

**6** Lower the Manhole Guardian™ into place over the open man hole. Ensure the Guardian is seated well on the ground.

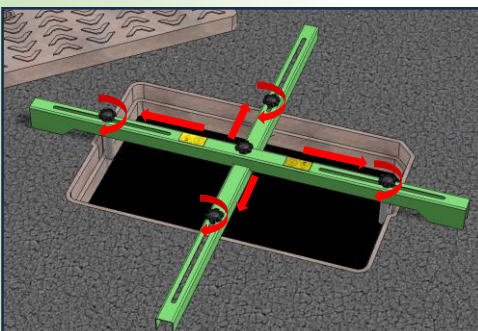

**7** Slide all 4 Location Posts to touch the inside of the manhole frame and tighten the 4 wheel bolts.

### Note:

Manhole Guardian™ is not PPE as it is designed for multiple personnel use in the way a manhole cover is. All tests have been conducted in line with how the Manhole Guardian™ is used to ensure worker safety.

Available to buy from [www.startsafety.uk](http://www.startsafety.uk)

**START > SAFETY**