

EASY TO USE

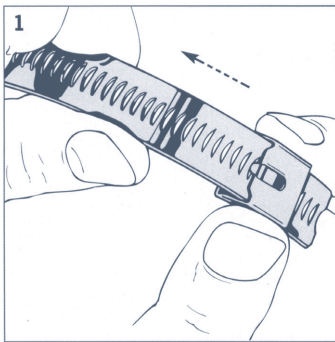

Slide the buckle onto the band in the direction of the arrow and push around to the housing.

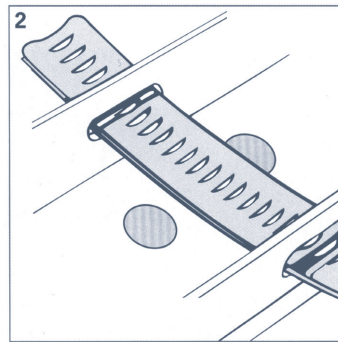

Thread the band through the slots in the sign and around post.

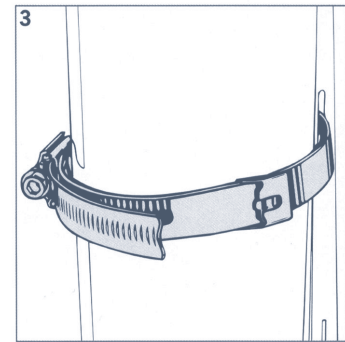

Engage the band into the screw housing and screw band through by approximately 50mm.

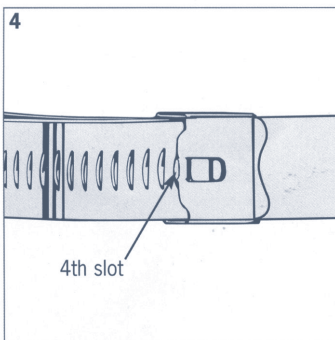

Locate the tongue of the buckle in the 4th slot of the band. Screw the band through using a hand or power tool.

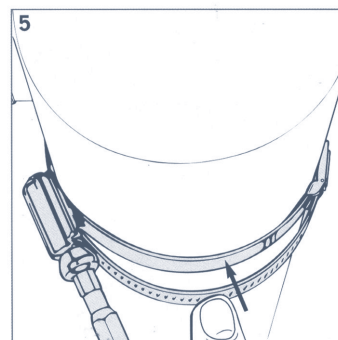

Hold down any excess band just before the buckle is clamped. Finally tighten with the ratchet spanner.

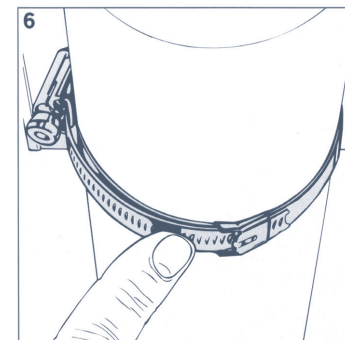

Push any remaining excess band through the buckle for a safe, tidy job. Tamtorque can be released and repositioned if required.

TAMTORQUE® TOOLS



RATCHET SPANNER

1/4" square ratchet driver complete with a tamtorque socket bit.



COMBI DRIVER

A screwdriver and T-bar combination tool with non-removable Tamtorque bit.



LONG REACH BIT

1/4" hex x 170mm long bit for direct insertion into cordless drill/drivers.



TOOL BIT

1/4" hex x 50mm long bit for direct insertion into cordless drill/driver. Two bits per bag.



SOCKET BIT

For use with the Tamtorque or other ratchet spanners.