

BANC MORA JUNIOR - Réf.299010 - 299011

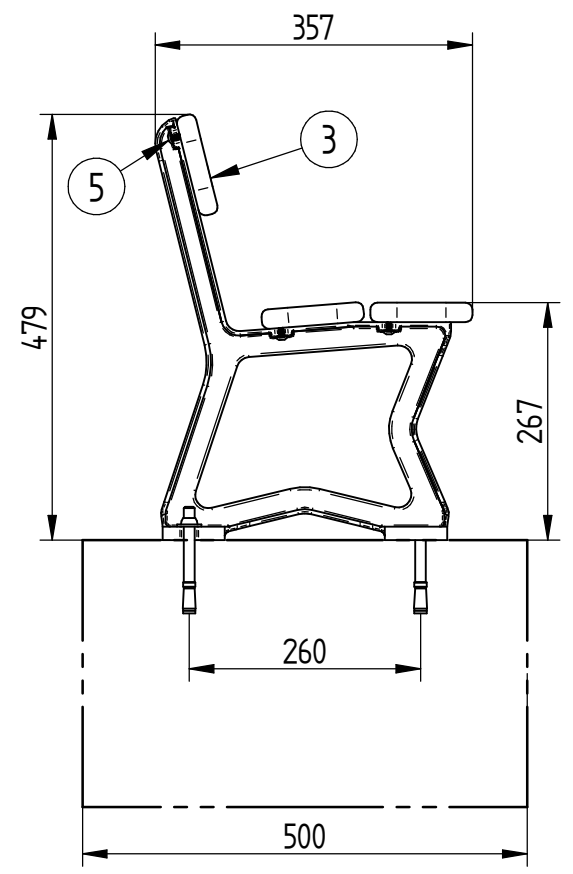
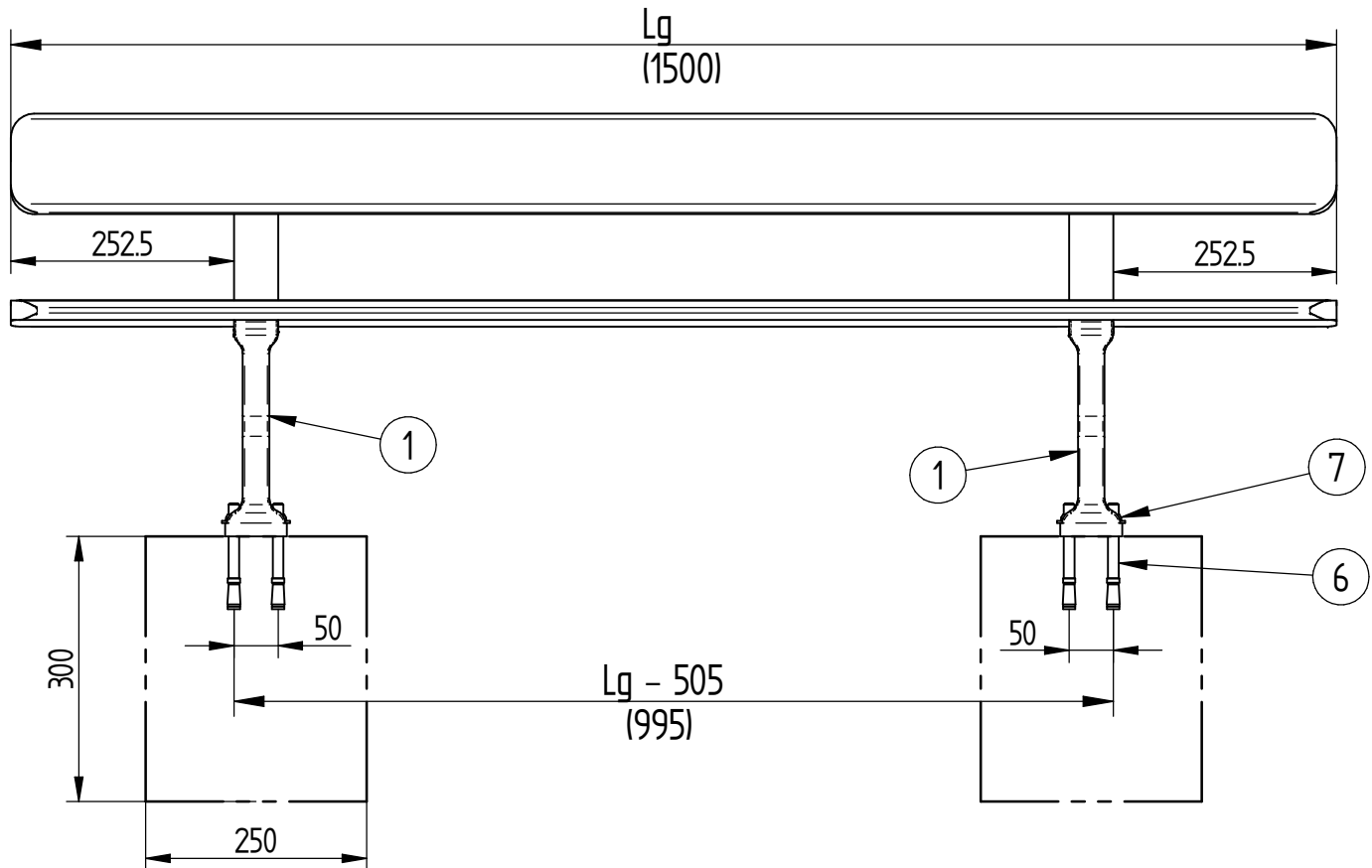

	10	ACC050408	1	Embout Vis Torx Inviolable T30
	7	ACC04999	4	Ecrou inviolable autocassant M12 A2
	6	ACC07061	4	Goujon M12x120 ZN
	5	ACC220305	12	Vis de Penture $\phi 6 \times 30$ Inox
	3	ACC11083	3	LAME DE BOIS ASSISE & DOSSIER BANC MORA JUNIOR
	1	MFB19089	2	PIED DE BANC MORA JUNIOR
X	N°	Références	Qté	Description

PROCITY

N° OF :

FRANCE: +33.(0)2.54.80.32.99
EXPORT: +33.(0)1.39.08.26.55

